

GET Turbine Generator

... the innovation that pays you back!

- **high degree of efficiency**
- **small, compact and robust**
- **low maintenance**
- **low investment**

The unit, consisting of an expansion turbine and generator is the optimal decentralised energy recovery system for power ranges between 1 kW and 120 kW.

The small robust and compact turbine generator – not much larger than a shoebox – can be installed decentrally anywhere where small amounts of residual energy have previously been left unused after industrial processing. The innovative technology can be implemented in a variety of applications to convert process gas or utilise waste heat.

Green Energy



■ **Best degree of efficiency**

The turbine unit is designed precisely for your specific processing conditions. The degree of efficiency attained can be up to 80% and is therefore substantially higher than when using standard machines such as reciprocating engines or expanders.

■ **Small, compact and rugged**

Without the associated recovery unit, the turbine generator is not much bigger than a shoe box.

■ **Maintenance-free**

The turbine generator operates without any gearing between turbine and generator. The rotor of the generator is positioned directly on the shaft with the turbine wheel which drives it.

■ **Low investment**

Using our own calculation programme, the turbine unit can be designed in no time at all. We are able to rely on a standard modular kit for the generator components.



5 kW Turbine

FUNCTIONAL PRINCIPLE

Our turbines are turbo machines which can be used single-stage axially or radially.

Gas expands in the jets and undergoes powerful acceleration. Once it meets the turbine blading and is redirected, it yields its kinetic energy.

The axial turbine is distinguished by a high degree of efficiency even outside nominal operating conditions. This enables particularly economic operation even if only partially loaded.

In contrast, the radial turbine can reach an even higher degree of efficiency directly at the design point. The gas in this case is only partially expanded in the jets. The rest of the expansion and redirection takes place in the turbine wheel. The degree of efficiency if operated partially loaded is comparatively less than the axial design.

UTILIZATION PRINCIPLE

Direct Usage

During a direct usage, the energy is recovered through the pressure drop and converted into electric energy.

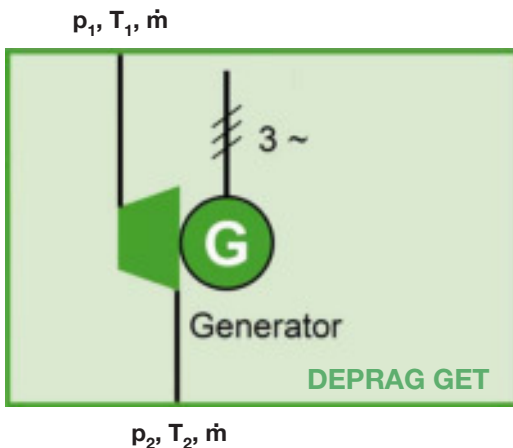

Indirect Usage

During an indirect usage, the unused heat is recovered through a closed process (for example an ORC-process) and converted into electric energy.

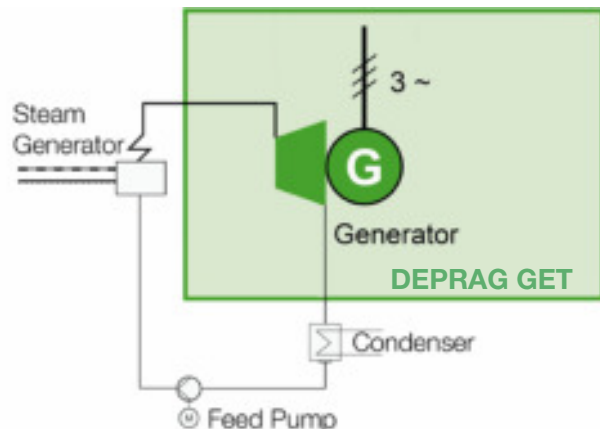

Power range	3 – 175 kW electric
Sizes	5 kW, 30 kW, 60 kW (ATEX), 120 kW, 175 kW
Processes	- open process - closed process
Mediums	compressed air, CO ₂ , water steam, natural gas, refrigerants e.g. R245fa, R1336mzz, R134a, NOVEC 649, siloxanes, cyclopentane and others
Outlet temperature	max. 150°C (depending on medium)
Preconditions	- dry - free from pollution



120 kW Turbine

All our turbines are designed and built according to each application case (medium, pressures, temperatures, mass flow).

In order for us to be able to provide a quotation it is therefore necessary for the last page of the questionnaire form to be filled in.

DIMENSION SHEET

5kW

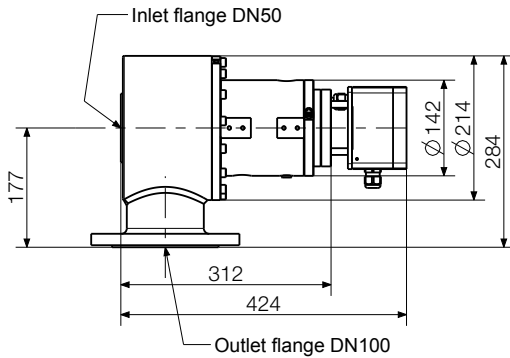

30kW

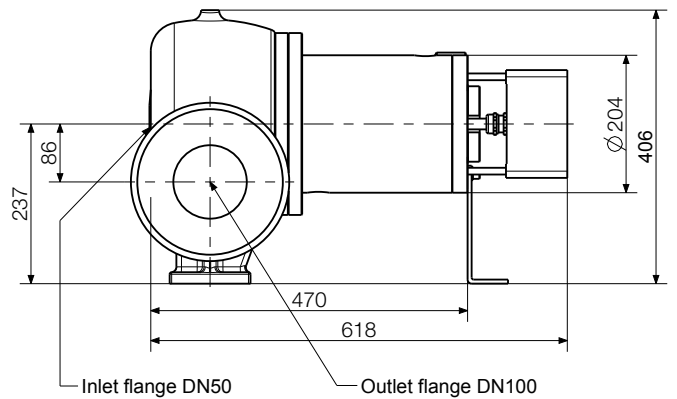

60kW

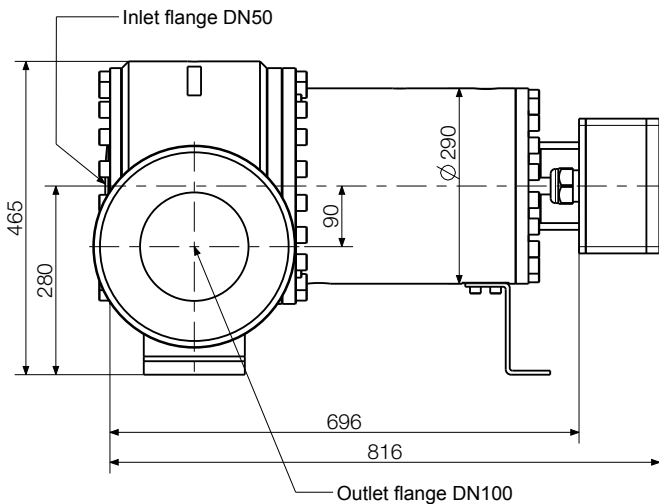

120kW

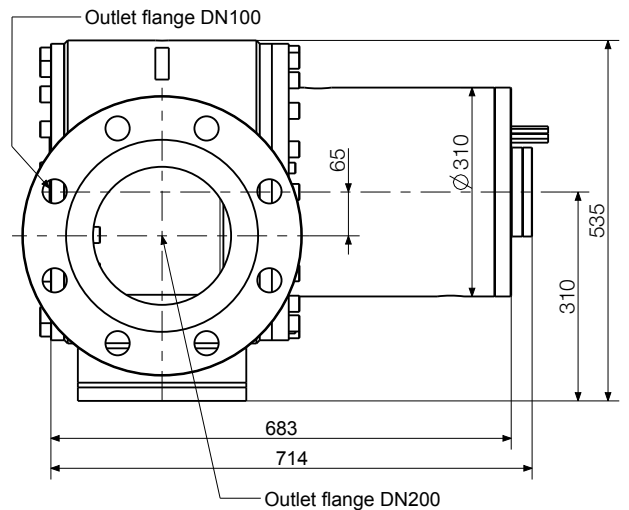

EXAMPLES FOR ENERGY RECOVERY

When smelting metals – for example, aluminium or copper – the melting tanks are cooled using compressed air. The compressed air flows through cooling ducts and gathers heat in the process. Then it is normally released unused into the atmosphere.

The new turbine generator enables utilisation of the energy absorbed in the heat: With the micro-expansion turbine and the intelligent generator, the unused energy is converted into electric current and fed back into the power network.

Example compressed air:

Mediums: Compressed air
Inlet pressure $p_1 = 5$ bar (abs.)
Outlet pressure $p_2 = 1$ bar (abs.)

Inlet temperature $T_1 = 120^\circ\text{C}$
Mass flow: $m = 0.15$ kg/s
Achieved electrical power = 13.6 kW

Smelting plants



In some large biogas plants residual energy is already being converted, though only in systems with a power range of 200 to 1,500 kW.

The DEPRAG technology now enables energy recovery in smaller plants as well.

To further increase efficiency of biogas plants methane can be fed into the natural gas network and energy can thereby be stored or transported. A large part of biogas is methane and carbon dioxide. A pre-requisite for the feed-in is therefore that the carbon dioxide is removed from the biogas.

This usually occurs in those processing plants where carbon dioxide is present at the end stage at relatively high pressure and temperature levels. A large amount of the energy contained can be recovered using our GET.

Biogas plants



Natural gas is pumped from the producing countries over thousands of kilometres to get to the consumer. To feed it into the regional networks in which low pressure prevails, the pressure must be decreased and the gas expanded. The domestic public services also reduce the gas pressure once more before the natural gas arrives in private households.

The transformation of pressures in the gas lines means that valuable energy is being lost in the gas grid.

The DEPRAG GET turbine generator converts this energy into electric current, cost-effectively and without a large outlay.

The natural gas cools drastically due to expansion in the turbine. Natural gas must usually be preheated if the gas temperature should be above freezing after going through the turbine.

Natural gas network



Heat energy can come from natural deposits (geothermal), industrial processes (e.g. foundries) or from stationary or mobile combustion engines (e.g. thermal power stations, ship motors, HGVs ...). Around 60% of the energy used in combustion engines is lost through dissipated heat in the radiator and exhaust flow!

In order to make use of this wasted energy the GET turbine generator is clearly worth installing in e.g. ORC systems.

The unused heat energy is converted into electricity and can be used for its own purposes or can be fed into the power network.

Example refrigerant:

Mediums: R245fa
Inlet pressure $p_1 = 7.4$ bar (abs.)
Outlet pressure $p_2 = 1.6$ bar (abs.)

Inlet temperature $T_1 = 80^\circ\text{C}$
Mass flow: $m = 1.9$ kg/s
Achieved electrical power = 37.3 kW

Thermal energy

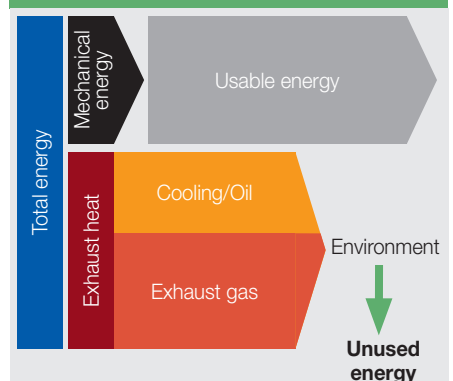

INQUIRY FORM TURBINE GENERATOR

Do you need support in selecting a turbine generator system for your application?

Tell us your operational conditions and our application engineers will be happy to support you.

Fill in the following inquiry and send it to greenenergy@deprag.de or directly on our website: www.deprag.com/en/green-energy/inquiry/

DEPRAG
machines unlimited



<p>Application / Process description:</p>	
<p>* Medium (type of gas, fluid):</p>	
<p>* Inlet pressure (absolute)</p>	
<p>* Outlet pressure (absolute)</p>	
<p>* Inlet temperature or outlet temperature</p>	
<p>* Mass flow or required electrical power</p>	
<p>Operating conditions: Duty cycle in hours per year</p>	
<p>Demand: Annual usage Costing / Budget</p>	
<p>Personal data:</p>	
<p>* Name</p>	
<p>* Company</p>	
<p>Street</p>	
<p>ZIP / City</p>	
<p>* Country</p>	
<p>Phone</p>	
<p>* Email</p>	
<p>Web page / URL</p>	

* mandatory field

Distributed in the Netherlands by:



Zumpolle bv • Valeton 14 • 5301 LW Zaltbommel • Tel: 0031418671816

DEPRAG
DEPRAG SCHULZ GMBH u. CO.

CERTIFIED ACCORDING TO DIN EN ISO 9001